

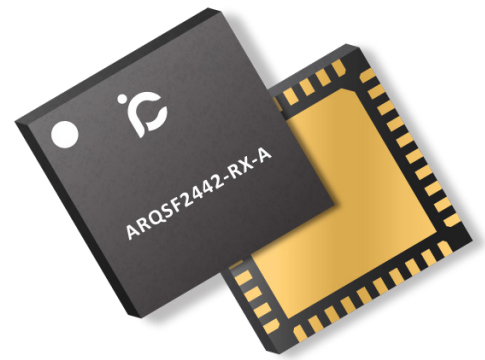

## 2.4 – 4.2 GHz DUAL-CHANNEL RECEIVER FRONT-END MODULE

**ARQSF2442-RX-A** is a dual-channel, receiver front-end module (FEM) designed for 3GPP 5G NR FR1 bands n7, n38, n41, n48, n53, n77, n78, and n90 Wireless Infrastructure. Each channel consists of a silicon SPDT switch and a two-stage GaAs LNA with bypass. The LNA provides high and low gain modes with 1.3 dB noise figure. The SPDT supports high power input signals up to 12 W average power with 10 dB PAR.

This FEM is part of iCana's compact pin-to-pin compatible FEM product line designed for Wireless Infrastructure supporting major 3GPP bands.



40 Pad 6 × 6 mm<sup>2</sup> SMT Package

### Key Features

#### Transmit Operation:

- Power handling: 41 dBm average power (LTE signal, 10 dB PAR)
- Low insertion loss: 0.7 dB
- Tx-Rx isolation: > 65 dB (ANT to RXOUT, LNA power down)
- Channel isolation: > 50 dB (TERM to TERM)

#### Receive Operation:

- Amplification with by-pass: High gain = 37 dB, Low gain = 16 dB
- Low current consumption: High gain = 115 mA, Low gain = 45 mA
- Low noise figure: 1.3 dB
- Excellent linearity: OIP3 = 33 dBm
- Positive logic control voltage: 1.8 V or 3.3 V
- Tx-Rx isolation: > 30 dB (ANT to TERM)
- Channel isolation: 40 dB (RXOUT to RXOUT)
- Package dimensions: 6 × 6 × 0.85 mm<sup>3</sup>

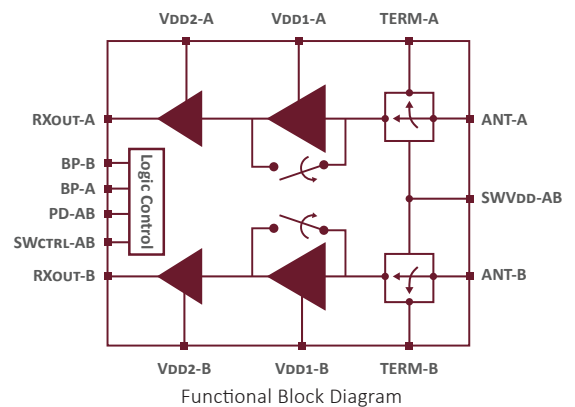

### Typical Applications

- 3GPP 5G NR FR1 bands n7, n38, n41, n48, n53, n77, n78, and n90
- 5G NR FR1 and 4G LTE massive MIMO
- Wireless infrastructure
- FDD- and TDD-based communication systems

### Ordering Guide

Part Name	Description
ARQSF2442-RX-A	2.4 – 4.2 GHz Dual-Channel Receiver Front-End Module
ARQSF2442-RX-A-EVB	Evaluation Board for ARQSF2442-RX-A

### 5G NR FR1 FEM Product Line

Product Name	Description
ARQSF2442-RX-A	2.4 – 4.2 GHz
ARQSF2442-RX-B	2.4 – 4.2 GHz
ARQSF3753-RX-A	3.7 – 5.3 GHz
ARQSF3753-RX-B	3.7 – 5.3 GHz