

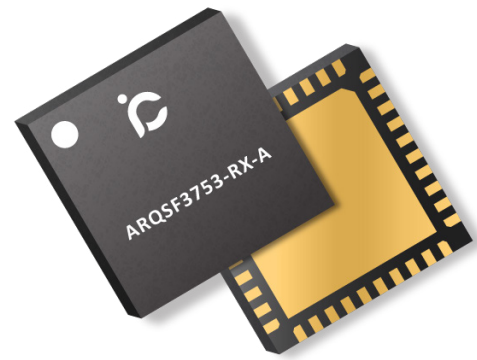

3.7 – 5.3 GHz DUAL-CHANNEL RECEIVER FRONT-END MODULE

ARQSF3753-RX-A is a dual-channel, receiver front-end module (FEM) designed for 3GPP 5G NR FR1 bands n77 and n79 Wireless Infrastructure. Each channel consists of a silicon SPDT switch and a two-stage GaAs LNA with bypass. The LNA provides high and low gain modes with 1.6 dB noise figure. The SPDT supports high power input signals up to 12 W average power with 10 dB PAR.

This FEM is part of iCana’s compact pin-to-pin compatible FEM product line designed for Wireless Infrastructure supporting major 3GPP bands.



40 Pad 6 × 6 mm² SMT Package

Key Features

Transmit Operation:

- Power handling: 41 dBm average power (LTE signal, 10 dB PAR)
- Low insertion loss: <0.5 dB
- Tx-Rx isolation: > 60 dB (ANT to RXOUT, LNA power down)
- Channel isolation: > 50 dB (TERM to TERM)

Receive Operation:

- Amplification with by-pass: High gain = 37 dB, Low gain = 16 dB
- Low current consumption: High gain = 115 mA, Low gain = 45 mA
- Low noise figure: 1.6 dB
- Excellent linearity: OIP3 = 29 dBm
- Positive logic control voltage: 1.8 V or 3.3 V
- Tx-Rx isolation: 30 dB (ANT to TERM)
- Channel isolation: 35 dB (RXOUT to RXOUT)
- Package dimensions: 6 × 6 × 0.85 mm³

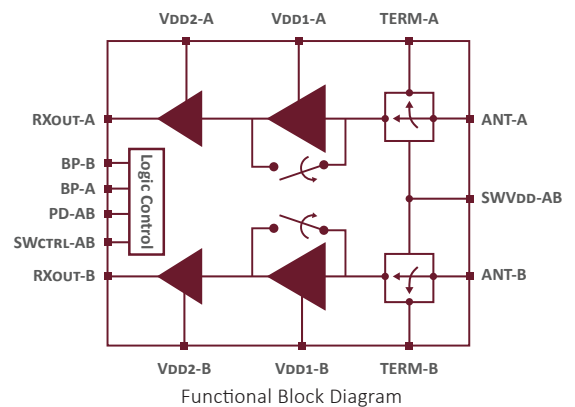

Typical Applications

- 3GPP 5G NR FR1 bands n77 and n79
- 5G NR FR1 and 4G LTE massive MIMO
- Wireless infrastructure
- FDD- and TDD-based communication systems

Ordering Guide

Part Name	Description
ARQSF3753-RX-A	3.7 – 5.3 GHz Dual-Channel Receiver Front-End Module
ARQSF3753-RX-A-EVB	Evaluation Board for ARQSF3753-RX-A

5G NR FR1 FEM Product Line

Product Name	Description
ARQSF2442-RX-A	2.4 – 4.2 GHz
ARQSF2442-RX-B	2.4 – 4.2 GHz
ARQSF3753-RX-A	3.7 – 5.3 GHz
ARQSF3753-RX-B	3.7 – 5.3 GHz

DISCLAIMER

All Rights Reserved. Copyright ©2022 iCana Ltd. All information in this document is provided in connection with iCana Ltd. ("iCana") products as a service to its customers and may be used for informational purposes only. iCana assumes no responsibility for errors or omissions in this information contained and iCana may change its documentation, products, specifications or product descriptions at any time, without prior notice.