



ARQSP3437-4

PRODUCT SUMMARY



3.4 – 3.7 GHz 4 W HIGH-EFFICIENCY POWER AMPLIFIER

ARQSP3437-4 is a high-efficiency DPD-friendly Power Amplifier fabricated for 5G NR FR1 bands n48, n77, and n78 Wireless Infrastructure. This Power Amplifier is fully matched at input and output. It is realized in GaAs technology and overmolded in a compact 16-pin 5 × 5 mm² LGA package.

This amplifier is part of iCana's high-efficiency 4 W PA RF product line designed for Wireless Infrastructure supporting major 3GPP bands.



16 Pad 5 × 5 mm² LGA Package

Key Features

- Frequency range: 3400 – 3700 MHz
- 50 Ω matched input and output
- High efficiency: PAE = 23.9% @ P_{OUT} = 28 dBm
- High linearity: ACLR < -49 dBc @ P_{OUT} = 28 dBm with digital pre-distortion (5G signal, BW = 100 MHz)
- High output power: P_{SAT} = 35.4 dBm
- High power gain: 37.6 dB
- Single supply voltage: V_{CC} = 5.0 V
- Pin-to-pin compatible PA family for 3GPP 5G NR FR1
- Compact package size: 5.0 × 5.0 × 1.1 mm³

Typical Applications

- 3GPP 5G NR FR1 bands n48, n77, and n78
- 3GPP 4G LTE bands 42, 48, 49, and 52
- FDD and TDD systems
- Small cells for wireless communications infrastructure
- Repeaters / DAS
- General purpose wireless

Ordering Guide

Part Name	Description
ARQSP3437-4	3.4 – 3.7 GHz 4 W High-Efficiency Power Amplifier
ARQSP3437-4-EVB	Evaluation Board for ARQSP3437-4

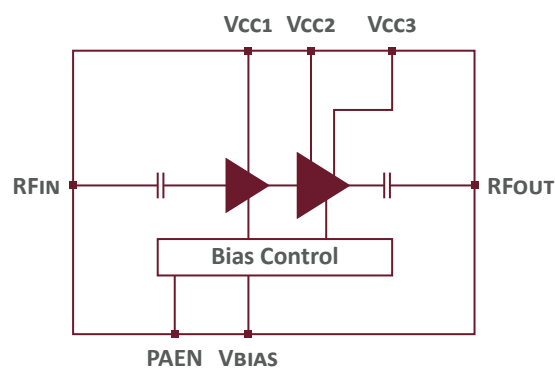

Functional Block Diagram

5G NR FR1 4 W PA Product Line

Product Name	Frequency Range (GHz)	5G Bands
ARQSP1819-4	1.8 – 1.9	n3, n39
ARQSP2122-4	2.1 – 2.2	n1
ARQSP2324-4	2.3 – 2.4	n30, n40
ARQSP2527-4	2.5 – 2.7	n7, n38, n41
ARQSP3336-4	3.3 – 3.6	n77, n78
ARQSP3437-4	3.4 – 3.7	n48, n77, n78
ARQSP3742-4	3.7 – 4.2	n77
ARQSP4450-4	4.4 – 5.0	n79

REV 1.0

DISCLAIMER

All Rights Reserved. Copyright ©2022 iCana Ltd. All information in this document is provided in connection with iCana Ltd. ("iCana") products as a service to its customers and may be used for informational purposes only. iCana assumes no responsibility for errors or omissions in this information contained and iCana may change its documentation, products, specifications or product descriptions at any time, without prior notice.

iCana Ltd.

5F, No. 28-2, Baogao Road, Xindian District,
New Taipei City 231, Taiwan (ROC)

icana-rf.com