



ICASP3338-20

PRODUCT SUMMARY



3.3 – 3.8 GHz 20 W HIGH EFFICIENCY POWER AMPLIFIER

ICASP3338-20 is a high-efficiency DPD-friendly Power Amplifier which provides a saturated power of 20 W and average power of 3 W. It is fabricated for 5G NR FR1 bands n48 (CBRS), n77, and n78 Wireless Infrastructure. This Power Amplifier is fully matched at input and output. It is realized in GaN technology and overmolded in a compact 36-pad $6 \times 10 \text{ mm}^2$ LGA package.

This amplifier is part of iCana's high-efficiency 20 W PA RF product line designed for Wireless Infrastructure supporting major 3GPP bands.



36 Pad $6 \times 10 \text{ mm}^2$ LGA Package

Key Features

- Frequency range: 3300 – 3800 MHz
- 50Ω matched input and output
- High efficiency: PAE = 30.2% @ PAVG = 35 dBm
- High linearity: ACLR < -50 dBc @ PAVG = 35 dBm with digital pre-distortion (5G signal with BW = 100 MHz)
- High output power: P3dB = 45.1 dBm (3 dB PAR compression)
- High large signal gain: 28 dB
- Drain voltage: VDD = 28 V
- Pin-to-pin compatible PA family for 3GPP 5G NR FR1
- Compact package size: $6.0 \times 10.0 \times 1.1 \text{ mm}^3$

Typical Applications

- 3GPP 5G NR FR1 bands n48 (CBRS), n77, and n78
- FDD and TDD systems
- Small cells for wireless communications infrastructure
- Repeaters / DAS
- General purpose wireless

Ordering Guide

Part Name	Description
ICASP3338-20	3.3 – 3.8 GHz 20 W High-Efficiency Power Amplifier
ICASP3338-20-EVB	Evaluation Board for ICASP3338-20

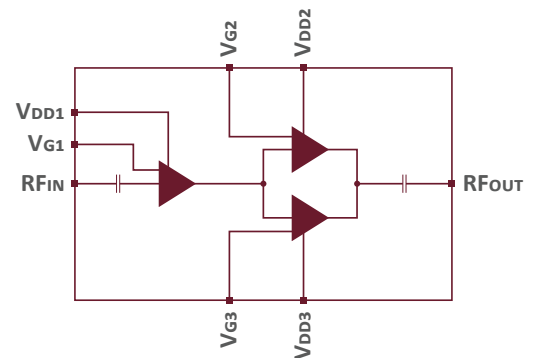

Functional Block Diagram

5G NR FR1 20 W PA Product Line

Product Name	Frequency Range (GHz)	5G Bands
ICASP3338-20	3.3 – 3.8	n48, n77, n78
ICASP3742-20	3.7 – 4.2	n77
ICASP4450-20	4.4 – 5.0	n79

REV 1.0

DISCLAIMER

All Rights Reserved. Copyright ©2023 iCana Ltd. All information in this document is provided in connection with iCana Ltd. ("iCana") products as a service to its customers and may be used for informational purposes only. iCana assumes no responsibility for errors or omissions in this information contained and iCana may change its documentation, products, specifications or product descriptions at any time, without prior notice.

iCana Ltd.

5F, No. 28-2, Baogao Road, Xindian District,
New Taipei City 231, Taiwan (ROC)

icana-rf.com

Page

1